

NDA-7040-PIP Pendant interface plate, 158mm



This camera-specific accessory is designed for use with Bosch's line of universal accessories. The modular camera mounts & accessories are a family of mounts, mounting adapters, pendant interface plates and surveillance cabinets which can be used with a wide range of Bosch cameras. The accessories are easy to install and can be combined to simplify installation in multiple locations while retaining the same look and feel.

Functions

The NDA-7040-PIP is designed especially for indoor use with the FLEXIDOME IP 6000/7000 family. It provides a safe and robust solution to mount the camera to:

- NDA-U-WMT Pendant wall mount
- NDA-U-PMT Pendant pipe mount

Certifications and approvals

Environmental	
Salt mist	IEC60068-2-52
Vibration	NEMA TS2
Shock	IEC60068-2-27
Impact	IK10

- ▶ Modular design for fast and easy installation
- ▶ One accessory line for multiple camera families from Bosch
- ▶ Weather resistant finish to maintain cosmetic appearance
- ▶ Allows installation of your camera to a wall mount (NDA-U-WMT) or pendant pipe mount (NDA-U-PMT)

Installation/configuration notes

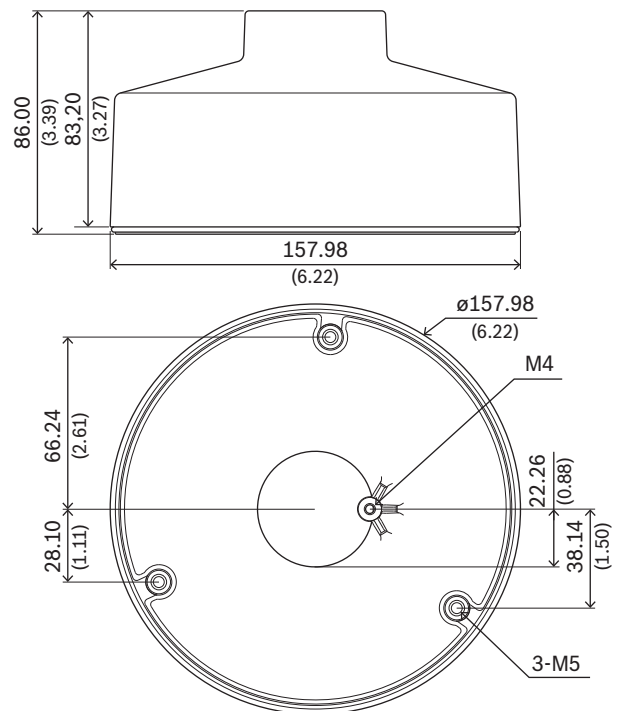

Dimensions in mm (in.)

Parts included

Quantity	Component
1	Pendant interface plate
3	M5 T25 screw

Quantity	Component
1	M4 T25 screw
1	Quick installation guide

Technical specifications

Dimension (Ø x H) (mm)	157,98 mm x 86 mm
Dimension (Ø x H) (in)	6,21 in. x 3,38 in.
Weight (g)	220 g
Weight (lb)	0.49 lb
Color in RAL	RAL 9003 Signal white
Material	Aluminum

Ordering information

NDA-7040-PIP Pendant interface plate, 158mm

Pendant interface plate for the FLEXIDOME IP
6000/7000 families

Order number **NDA-7040-PIP | F.01U.391.128**

Represented by:

Europe, Middle East, Africa:
Bosch Security Systems B.V.
P.O. Box 80002
5600 JB Eindhoven, The Netherlands
Phone: + 31 40 2577 284
emea.securitysystems@bosch.com
emea.boschsecurity.com

Germany:
Bosch Sicherheitssysteme GmbH
Robert-Bosch-Ring 5
85630 Grasbrunn
Germany
www.boschsecurity.com

North America:
Bosch Security Systems, LLC
130 Perinton Parkway
Fairport, New York, 14450, USA
Phone: +1 800 289 0096
Fax: +1 585 223 9180
onlinehelp@us.bosch.com
www.boschsecurity.us

Asia-Pacific:
Robert Bosch (SEA) Pte Ltd, Security Systems
11 Bishan Street 21
Singapore 573943
Phone: +65 6571 2808
Fax: +65 6571 2699
apr.securitysystems@bosch.com
www.boschsecurity.asia